

AMETHYST FLA HIGH MAST



LED HIGH MAST RANGE

PRODUCT SPECIFICATION SHEET



AMETHYST FLA HIGH MAST 100W-200W - SMALL HOUSING

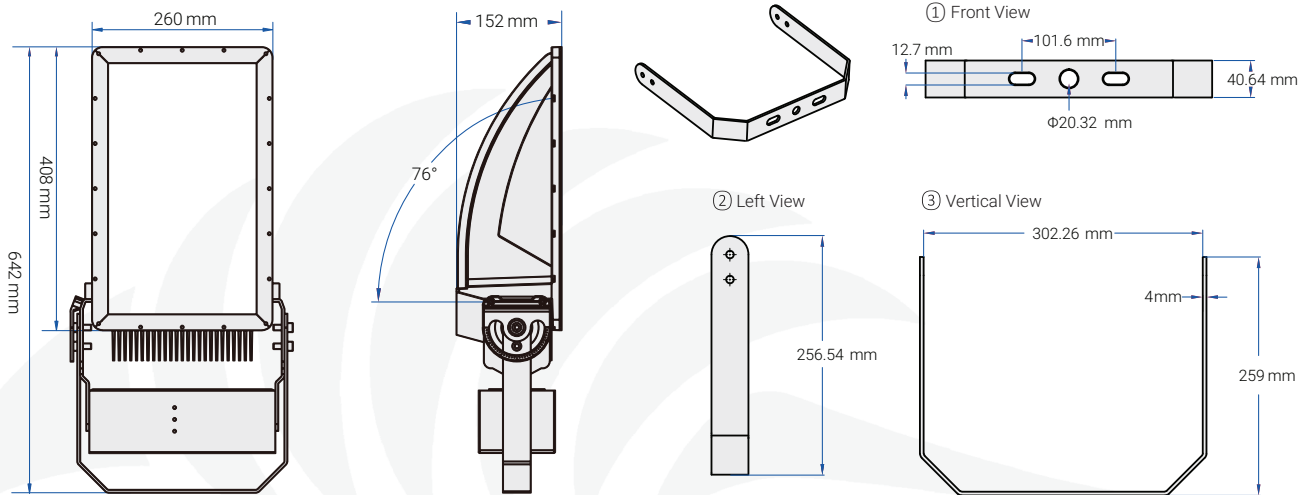

FEATURES:

- Latest LED chipset technology achieving up to 160lm/W
- Latest low glare PVD Reflector technology
- 100W-200W LEDs to replace equivalent of 250W-500W metal halide lamps
- Outstanding saving compared to metal halide lamps
- Easy Maintenance
- 5 year Warranty

SPECIFICATIONS:

- Facade lighting
- Area lighting
- Security lighting
- General floodlighting
- IP Rating: IP65
- Housing: Marine grade aluminium
- Installation height: Up to 30m
- Chlorine Protection System
- Max Windage Area (m) = 0.488
- Max SCx Values by Side (m) = 0.108
- Total Weight: 10.5 kg

ELECTRICAL SPECIFICATION:

- Input Voltage: 90-305V or 180-528V, 50/60Hz Class 1 Drivers
- Nominal Voltage: 100-265V 50-60Hz
- Power Factor: >0.9 at full load
- Total Harmonic Distortion: < 20% at full load
- Integral 10 kV surge protection as standard
- Electrical Class: III(**)
- Wattages: 100W-200W

PRODUCT DETAILS:

MODEL NUMBER	RATED POWER	INPUT VOLTAGE	LED	DRIVER	LUMINOUS FLUX	CCT	CRI	LIFE TIME	OPERATING TEMP.
AME-100-FLA	100W	90-305VAC/180-528VAC	Nichia	Meanwell	16.000lm	2700-7000K	80	50.000hrs	-40-70°
AME-200-FLA	200W	90-305VAC/180-528VAC	Nichia	Meanwell	32.000lm	2700-7000K	80	50.000hrs	-40-70°

AMETHYST FLA HIGH MAST



LED HIGH MAST RANGE

PRODUCT SPECIFICATION SHEET



AMETHYST FLA HIGH MAST 300W-400W - MEDIUM HOUSING

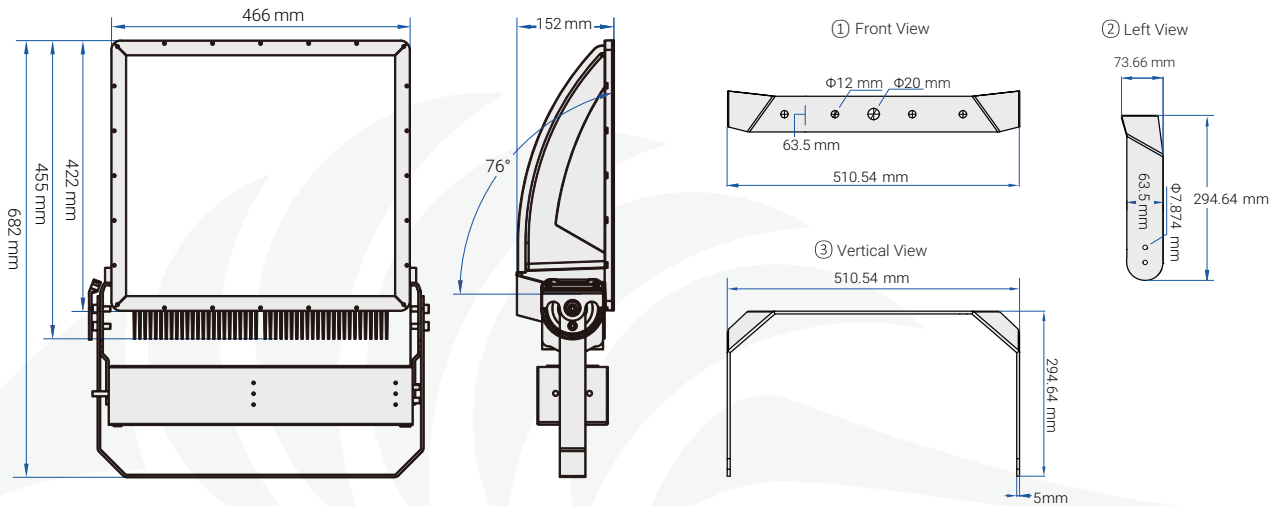

FEATURES: SPECIFICATIONS: ELECTRICAL SPECIFICATION:

- Latest LED chipset technology achieving up to 160lm/W
- Latest low glare PVD Reflector technology
- 300W-400W LEDs to replace equivalent of 750W-1000W metal halide lamps
- Outstanding saving compared to metal halide lamps
- Easy Maintenance
- 5 year Warranty

- Facade lighting
- Area lighting
- Security lighting
- General floodlighting
- IP Rating: IP65
- Housing: Marine grade aluminium
- Installation height: Up to 30m
- Chlorine Protection System
- Max Windage Area (m) = 0.318
- Max SCx Values by Side (m) = 0.07
- Total Weight: 19.5 kg

- Input Voltage: 90-305V or 180-528V, 50/60Hz Class 1 Drivers
- Nominal Voltage: 100-265V 50-60Hz
- Power Factor: >0.9 at full load
- Total Harmonic Distortion: < 20% at full load
- Integral 10 kV surge protection as standard
- Electrical Class: III(**)
- Wattages: 300W-400W

PRODUCT DETAILS:

MODEL NUMBER	RATED POWER	INPUT VOLTAGE	LED	DRIVER	LUMINOUS FLUX	CCT	CRI	LIFE TIME	OPERATING TEMP.
AME-300-FLA	300W	90-305VAC/180-528VAC	Nichia	Meanwell	48.000lm	2700-7000K	80	50.000hrs	-40-70°
AME-400-FLA	400W	90-305VAC/180-528VAC	Nichia	Meanwell	64.000lm	2700-7000K	80	50.000hrs	-40-70°

AMETHYST FLA HIGH MAST



LED HIGH MAST RANGE

PRODUCT SPECIFICATION SHEET



AMETHYST FLA HIGH MAST 500W-800W - LARGE HOUSING

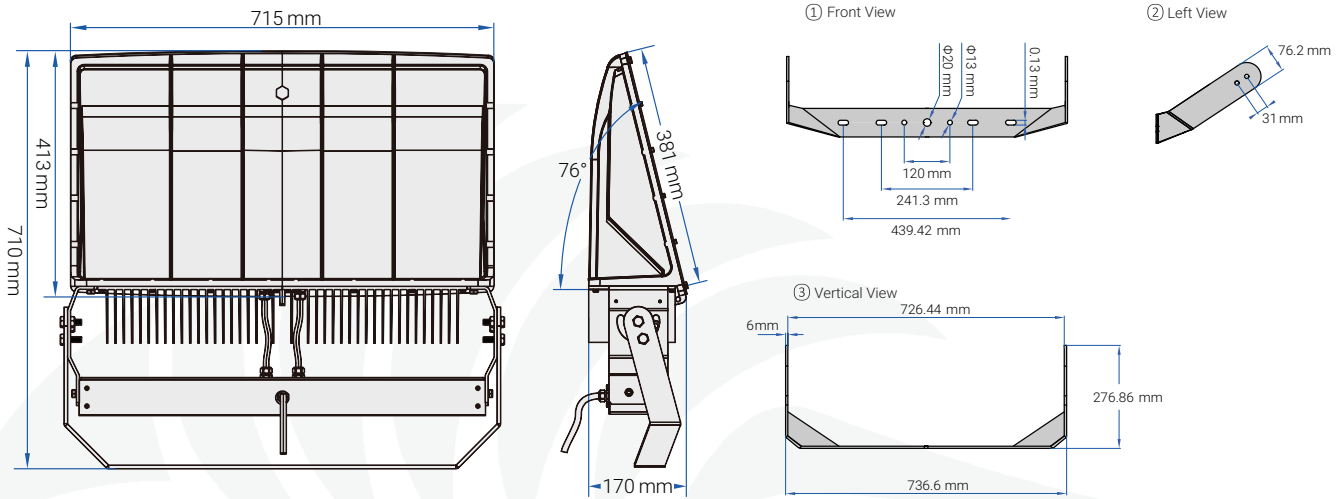

FEATURES:

- Latest LED chipset technology achieving up to 160lm/W
- Latest low glare PVD Reflector technology
- 500W-800W LEDs to replace equivalent of 1000W-1500W metal halide lamps
- Outstanding saving compared to metal halide lamps
- Easy Maintenance
- 5 year Warranty

SPECIFICATIONS:

- Applications: Roadway, Port, Airport, Railyard, Ship dock, Container & ferry terminal, parking lot, International boarder, Industrial and commercial site
- IP Rating: IP65
- Housing: Marine grade aluminium
- Instalation height: Up to 30m
- Chlorine Protection System
- Max Windage Area (m) = 0.167
- Max SCx Values by Side (m) = 0.039
- Total Weight: 33.5 kg

ELECTRICAL SPECIFICATION:

- Input Volatage: 90-305V or 180-528V, 50/60Hz Class 1 Drivers
- Nominal Voltage: 90-305V 50- 60Hz
- Power Factor: >0.9 at full load
- Total Harmonic Distortion: < 20% at full load
- Integral 10 kV surge protection as standard
- Electrical Class: III(**)
- Wattages: 500W-800W

PRODUCT DETAILS:

MODEL NUMBER	RATED POWER	INPUT VOLTAGE	LED	DRIVER	LUMINOUS FLUX	CCT	CRI	LIFE TIME	OPERATING TEMP.
AME-500-FLA	500W	90-305VAC/180-528VAC	Nichia	Meanwell	80.000lm	2700-7000K	80	50.000hrs	-40-70°
AME-600-FLA	600W	90-305VAC/180-528VAC	Nichia	Meanwell	96.000lm	2700-7000K	80	50.000hrs	-40-70°
AME-800-FLA	800W	90-305VAC/180-528VAC	Nichia	Meanwell	128.000lm	2700-7000K	80	50.000hrs	-40-70°